



HF/VHF AUTOMATIC ARDF TRANSMITTER

CONTEST 2007

instruction manual

INTRODUCTION

The CONTEST2007 automatic ARDF transmitter is designed for any level of ARDF competition or training. The possibility of frequency adjustment opens the new area in the ARDF competitions and allows using more transmitters on different frequencies. All parameters are widely adjustable via user-friendly menu on the detachable control panel while the transmitter itself is constructed as a high resistant, waterproof unit.

After features are set, the operation is very easy: just install the antenna, plug in the connector and transmitter automatically recognizes the proper band and starts operation. If antenna is disconnected, the transmitter turns off (all settings and time are preserved).

High capacity, lightweight Lithium-Ion accumulator provides enough capacity even for longer competitions.

IMPORTANT!

Read this instruction manual carefully before attempting to operate the transmitter.

Save this instruction manual. This instruction manual contains important safety and operating instructions for the CONTEST2007.

PRECAUTIONS

- ! NEVER** apply AC or more than 16V DC to any socket of the transmitter. This may cause fire or ruin the transmitter.
- ! NEVER** use any charger except for the one supplied by the manufacturer. You may ruin the accumulator or even the whole transmitter.
- ! NEVER** open the transmitter house, especially while in operation. There are no user serviceable parts inside! There are dangerous voltages across high-Q tank circuits inside the transmitter which may cause serious injuries.
- AVOID** using or placing the transmitter in the areas with temperatures below -20°C or above +60°C.

Use only accessories supplied by the manufacturer..

TABLE OF CONTENTS

INTRODUCTION	4	PARAMETER SETTING
IMPORTANT	■	General
PRECAUTIONS	■	Code and keying speed
TABLE OF CONTENTS	■	Timing schedule
UNPACKING	■	Frequency
	■	Power, language
1 PANEL DESCRIPTION	■	Real time clock
■ Transmitter front panel	■	Delayed operation
■ Control panel		
■ Basic setting: Operation mode	5 MAINTENANCE	
	■ Fuse replacement	
2 INSTALLATION	■ Charging	
■ Unpacking	■ Cleaning	
■ Before operating		
■ Transmitter philosophy	6 TROUBLESHOOTING	
■ Time base synchronization		
■ 3,5 MHz antenna installation	7 SPECIFICATIONS	
■ 144 MHz antenna installation		
■ Turning OFF	8 TECHNICAL INFORMATION	
3 OTHER FEATURES	9 OPTIONS	
■ Supply		
■ Band selecting	10 WARRANTY, SERVICE	

UNPACKING

The CONTEST2007 set contains:

- the transmitting unit itself
- detachable control panel
- antenna and counterpoise for 3,5 MHz band
- antenna and 2+2 elements for 144 MHz band
- TEST/TUNE button dongle
- this manual

1 PANEL DESCRIPTION

■ Transmitter front panel:

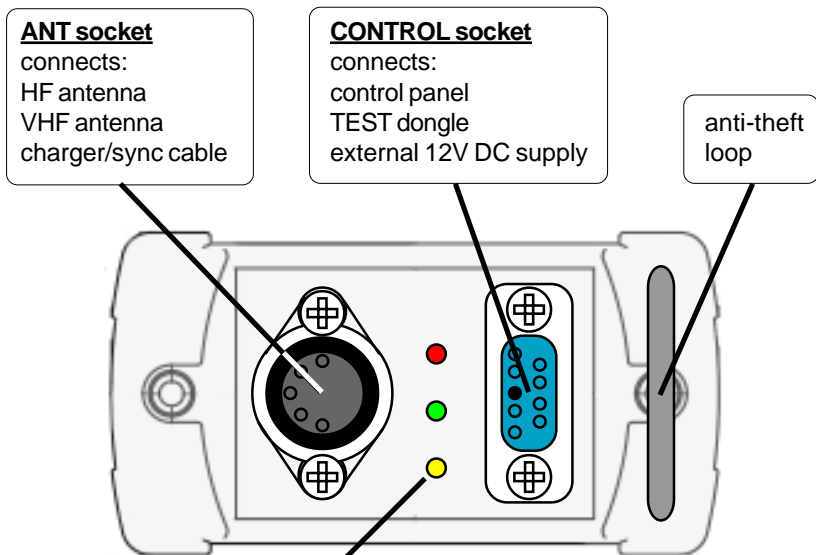

INDICATORS:

ANT (red): indicates RF power ON AIR

ACCU (green): indicates accumulator status:

- ■ ■ ■ accumulator full
- ■ ■ ■ > 80 % remains
- ● ● ● > 60 % remains
- ● ● > 40 % remains
- > 10 % remains
- no flash accumulator empty

CHARGE (yellow): indicates charging in process. As the accumulator is fully charged, the indicator goes off.

■ Control panel:

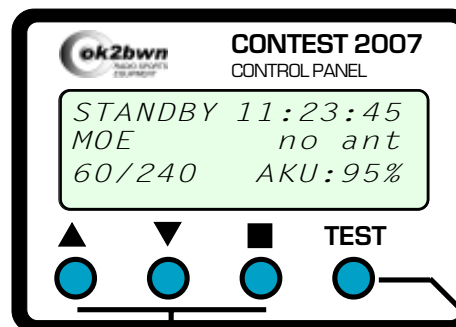

NOTE: in the following text

■ means pushing ENTER button,
▼ ▲ means pushing UP/DOWN button

UP/DOWN/ENTER buttons
mode setting,
moving between screens,
menu browsing/setting

TEST/TUNE button (equivalent to the button on the TEST dongle)
short click activates antenna tuner,
push and hold starts transmitting regardless of time and settings (checking)

■ Basic setting: Operation mode:

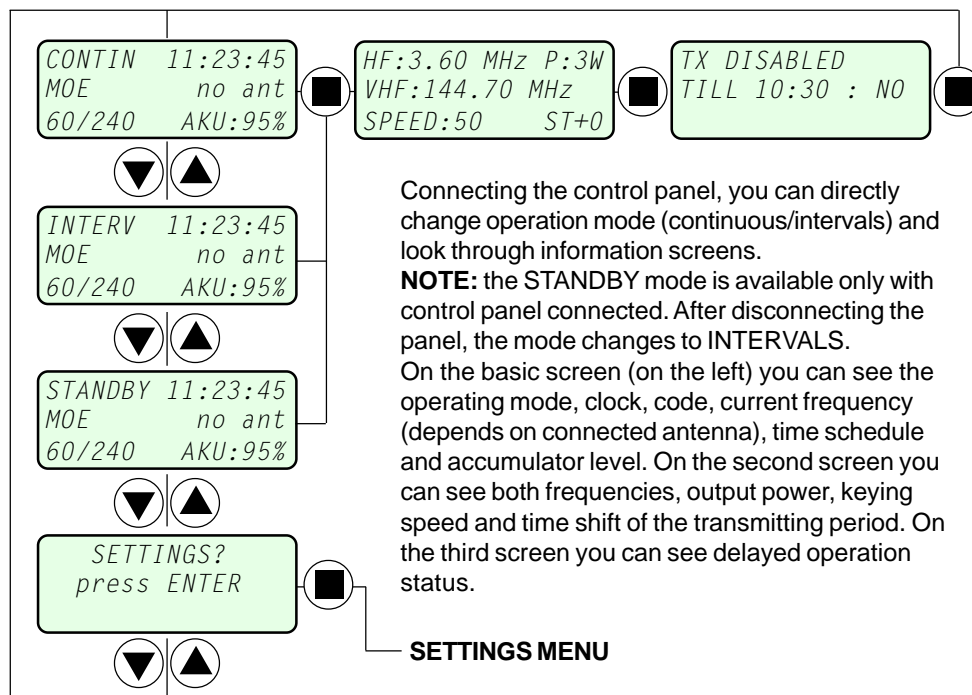

2 INSTALLATION

■ Unpacking

After unpacking, check carefully the transmitter and all accessories included. In the case of any damage do not use the transmitter and contact immediately the manufacturer.

■ Before operating

Before the first usage, charge the accumulator for 5 hours. You can use this time for reading of this instruction manual.

■ Transmitter philosophy:

The CONTEST2007 transmitter set contains of the transmitter unit itself and detachable control panel. At the field installation, only the antenna and resistant transmitting unit is placed in the forest - there is no chance of unwanted resetting.

If no external device (antenna, control panel etc.) is connected, the transmitter unit is in „sleeping“ state with almost zero consumption. All parameters information is stored and the real/time clock is running.

When you connect any device, internal processor wakes up, recognizes the device, reads information and starts operation according to the time and settings.

For example, you plan the competition for the next day. In the evening set the parameters (frequencies, time schedule, codes, power etc.) using the control panels. You can also set delayed operation, i.e. transmitters start operation from 10:30. Then disconnect the panel. Next day, the operators put the transmitters into the competition area, install and connect the antennas and it is all. With no further assistance, the transmitter network starts operating at 10:30 according to your settings. After competition, operator only disconnects the antenna and the transmitter shuts off, ready for further use.

■ Transmitter network time base synchronization

• One transmitter starting

Use SETTINGS>CURRENT TIME>HOURS>MINUTES, push **ENTER** exactly at the set time.

• Starting the set of transmitters by means of a synchrocable

1. Using SETTINGS>CURRENT TIME set the time with about 1 min accuracy
2. Connect grey connectors of the synchrocable to the **ANT** sockets.
3. Exactly at the beginning of the 5minute cycle (at 9:00, 9:05 etc.) push the **START** button on the synchrocable. All transmitters clocks will be set exactly to the nearest 5minute.
4. Disconnect the synchrocable from all transmitters.

■ HF antenna installation

HF antenna consists of a counterpoise (brown wire ended by a DIN connector) and the radiator itself (black wire ended by a banana plug).

Lay the counterpoise wire on the ground, straight towards the competition starting point. In case of the 3-radial counterpoise, lay the radials to all directions.

The radiator shall hang, for instance, from the tree branch. Use the whole length of the radiator if possible. During dry weather, the radiator may lay even on the tree trunk surface. During rain, when the trees are wet, the radiator shall better hang in a free space. Avoid close vicinity of large metal objects such as fences, rails or wires, which disturb the electromagnetic field and makes the finding difficult.

Plug the banana plug into the socket at the counterpoise wire and the DIN connector to the **ANT** socket on the front panel of the transmitter.

NOTE: It is advisable to turn the counterpoise once around the tree to prevent the plugs against whipping out when the competitor catches the counterpoise wire.

Automatic antenna tuning

Connect the **TEST** dongle or control panel to the transmitter and push the **TEST** button. The internal automatic antenna tuner will match the antenna. During the tuning procedure the **ANT** indicator shines continuously.

Manual antenna tuning

By the control panel, you can tune the antenna also manually. When the HF antenna is connected, the manual tuning feature appears in the basic setting cycle.

Push the **START** button. After a while (when the PLEASE WAIT prompt disappears), you can tune the antenna in both directions using the << and >> buttons. The output level is indicated in a digit and also by a bargraph. Try to reach the maximum - it may be a bit critical. Then release the buttons. After 2s delay, transmitter returns to the basic operation.

■ VHF antenna installation

VHF antenna consists of an antenna body with cable and four elements (two short and two long). Screw the elements into the antenna body - the shorter ones horizontally and the longer tilted. Hang the antenna on the tree branch by the string tied on the top of an antenna body. The coax cable shall lead vertically down.

Install the antenna as high as possible, 3 m at least. Plug the DIN connector to the **ANT** socket on the front panel. The VHF antenna needs no tuning. The **ANT** indicator shows only transmitted carrier.

After installation, you can check the transmitter setting using **TEST** dongle. Connect it and push and hold the button. The transmitter starts transmitting according the settings and connected antenna, but regardless of time. After releasing the button/ disconnecting the dongle, the transmitter continues in normal operation.

In the end, disconnect all devices except for antenna in order to avoid unwanted resetting.

3 OTHER FEATURES

■ Supply:

The transmitter is supplied by the built-in Lithium-Ion accumulator. As this accumulator is sensitive to the deep discharge, there is two stage protection and telemetric signalisation provided.

Under normal conditions (transmitter running, accumulator charged) there is green indicator flashing on the top panel. If the transmitter operates in intervals, every transmitting interval ends with a long dash showing the normal accumulator voltage. No dash found at the end of the relation means that the accumulator is exhausted and within next 10 to 30 minutes (according to the selected power and band) internal protection will disable the transmitter in order to prevent the accumulator from deep discharge. The transmitter referee could be warned in advance in order to use spare transmitter or external supply.

If the accumulator voltage sinks under higher limit (see above), the **ACCU** indicator on the front panel goes out and the transmitter switches to the LOW output power. When the voltage further decreases, the processor switches to the STANDBY mode. After normal accumulator voltage recovers (by connecting the external accumulator, for example), the transmitter continues in normal operation.

■ Band selecting:

The transmitter recognizes connected antenna and selects automatically the appropriate band. If no antenna is connected, the transmitter turns off.

■ Turning the transmitter OFF:

The transmitter turns off when no antenna or control panel is connected. All settings and real time clock are maintained. When the antenna is reconnected, the transmitter immediately returns to previous operation.

4 SETTINGS

■ General:

Any setting can be changed only with the control panel in the Setting menu.

Settings change: select the wanted menu part by the **UP/DOWN** buttons, then push **ENTER**. Parameter menu appears, current value flashes and can be changed by the **UP/DOWN** buttons. Confirm the chosen value by **ENTER**, which possibly moves you to the next menu item. Settings are stored in non-volatile memory when the **ENTER** button is pushed and remain there until they are again user-changed.

Return to the normal operation: push and hold the **ENTER** button or disconnect the control panel.

■ Timing schedule setting:

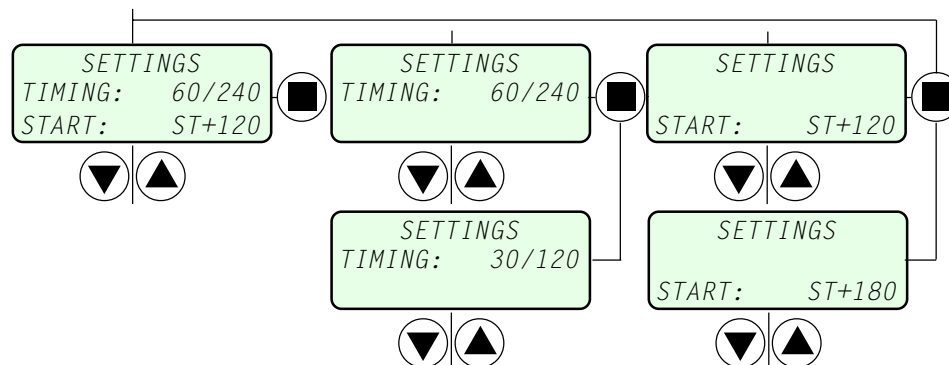

Timing schedule setting possibilities (sec. transmit/space): 60/240, 30/120, 30/270, 12/48, 15/45, 60/60, 30/30, 60/120, 30/60

The beginning of the transmitting interval can be shifted by any multiple of the interval along the whole cycle. The MOE, MO, A ... Z codes have the default setting +0, it means that the transmitting begins at the beginning of the cycle. The MOI ... MO5 codes are on default adequately shifted in the cycle. This offset can be, however, changed to any desired value. Resetting the code will reset also the offset to default.

All schedules start at the beginning of the hour (N:00:00).

■ Code, speed and tone setting:

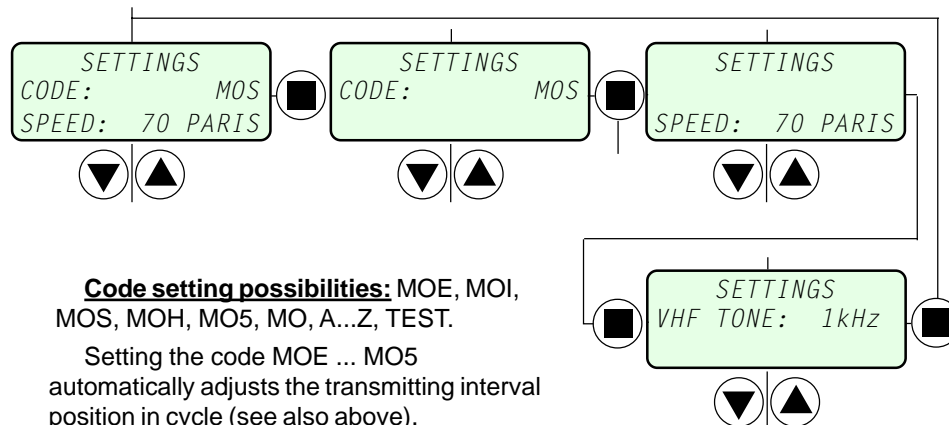

Code setting possibilities: MOE, MOI, MOS, MOH, MO5, MO, A...Z, TEST.

Setting the code MOE ... MO5 automatically adjusts the transmitting interval position in cycle (see also above).

NOTE: DO NOT USE THE TEST CODE! The TEST code is intended only for testing and diagnostic purpose. At this setting transmitter generates a continuous carrier, which is allowed only for a short time and into the defined load.

Keying speed setting possibilities: 35, 50, 70, 100 PARIS.

VHF modulation tone possibilities: 1000 Hz, 800 Hz, 1200 Hz.

■ **Frequency setting:**

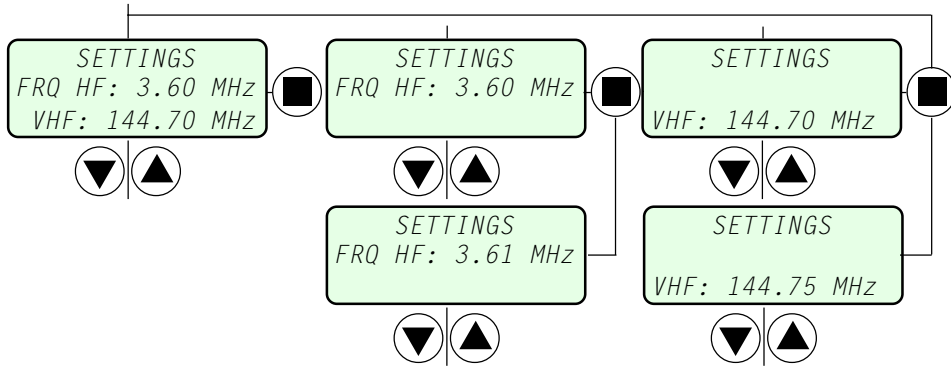

HF band frequency settings possibilities:

3,51 MHz	3,55 MHz	3,59 MHz	3,63 MHz
3,52 MHz	3,56 MHz	3,60 MHz	3,64 MHz
3,53 MHz	3,57 MHz	3,61 MHz	3,65 MHz
3,54 MHz	3,58 MHz	3,62 MHz	3,66 MHz

VHF band frequency settings possibilities:

144,10 MHz	144,50 MHz	144,80 MHz	145,30 MHz
144,20 MHz	144,60 MHz	144,85 MHz	145,40 MHz
144,30 MHz	144,70 MHz	144,90 MHz	145,50 MHz
144,40 MHz	144,75 MHz	145,20 MHz	145,55 MHz

NOTE: The band segment allocated for ARDF may differ from country to country. Check for local regulations and use only permitted channels.

■ **Power and language setting:**

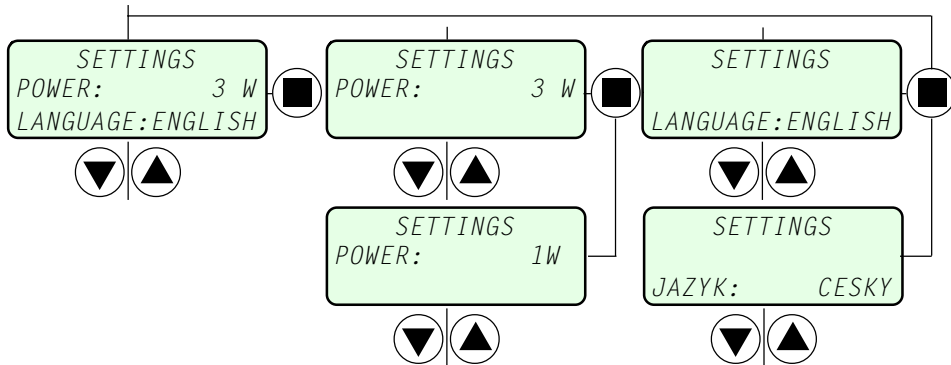

Power setting possibilities: 3W, 1W at HF, 3W, 1W PEP at VHF band..

Language possibilities: English, Czech.

■ **Real time clock setting:**

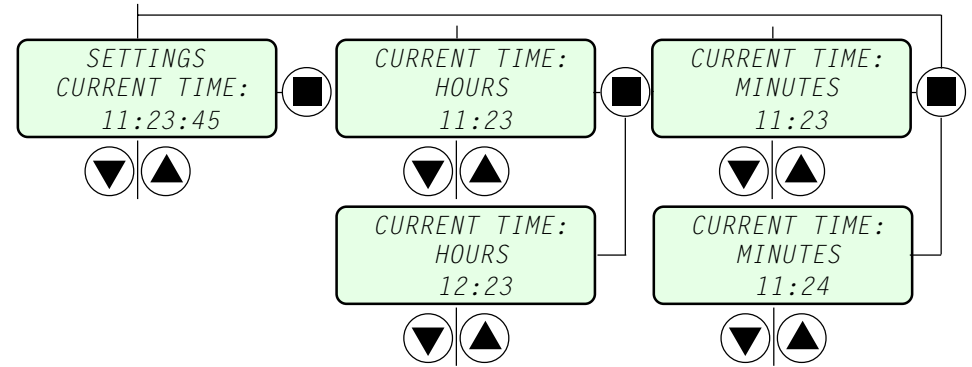

Confirming minutes resets the seconds.

For the whole transmitter network synchronization, use the synchronization cable (see also chapter 2: Time synchronization)

■ **Delayed operation setting:**

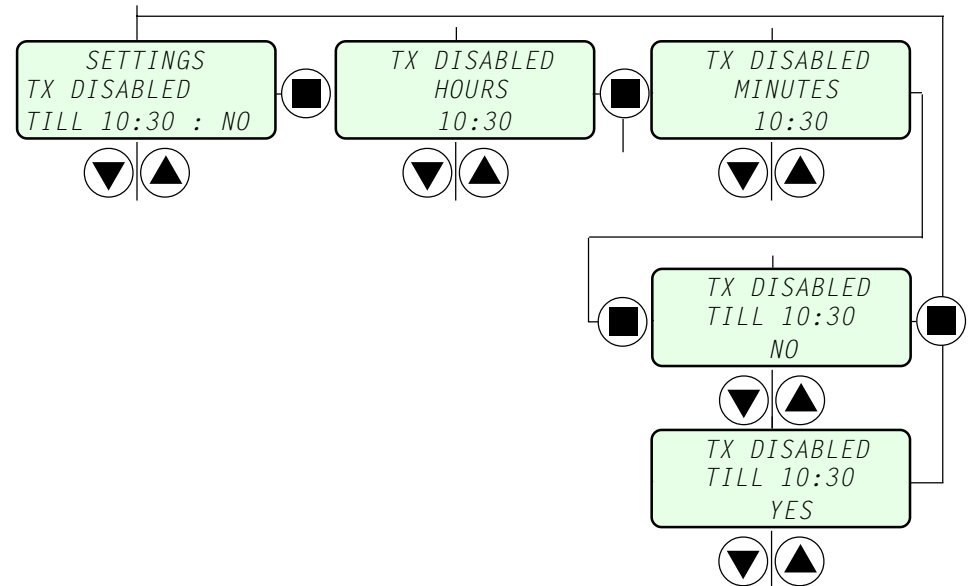

The time at which the transmitter shall commence operation, can be set to any time up to 24 hours in the future.

5 MAINTENANCE

■ **Fuse replacement:**

Accumulators are protected against shortcontact by two fuses o5x20mm, F2A. Replace the blown fuses with the ones of the same value only!

Procedure of fuse replacement:

1. Remove 2 screws on the rear panel of the transmitter and remove the panel.
2. Check for the blown fuse and replace it. If the new fuse blows out immediately, do not use the transmitter any more, close the rear panel and contact the manufacturer.
3. Close the rear panel and return the screws.

■ **Charging**

The charging period is 1-5 hours according to the discharge level. After the accumulators are charged, the charger automatically terminates charging. The transmitters may remain connected to the charger. The transmitter house may be a bit warm during the charging.

The charging source (12V/1A DC) shall be connected to the **ANT** socket.

While charging, the **CHARGE** (yellow) indicator shines. After the accumulator is fully charged, the indicator goes out.

Keep the accumulators fully charged. Charge them after every competition and also after the longer period of inactivity.

■ **Cleaning:**

Keep the transmitter dry and clean. If the transmitter becomes wet, dry it by the clean cloth and let it dry in a room temperature. **Never** use strong heaters!

If the transmitter becomes dusty or dirty, clean it with a brush or a dry, soft cloth. **Avoid** the use of strong chemical solvents such as benzine or alcohol to clean the transmitter.

The transmitter needs no maintenance above the mentioned procedures.

6 TROUBLESHOOTING

The following list is designed to help you correct problems which are not equipment malfunctions. If you are unable to locate the cause of a problem or solve it through the use of this list, contact the manufacturer.

■ **After connecting an antenna ACCU indicator flashes, but transmitter does not work**

Possible cause: disabled operation

Solution: connect the Control panel, check for settings

Possible cause: blown fuse

Solution: check for the possible cause, replace the fuse

■ **After connecting an antenna ACCU indicator does not flash and transmitter does not work**

Possible cause: exhausted accumulator

Solution: connect the Control panel, check for the accumulator voltage, recharge the accumulator

Possible cause: blown fuses

Solution: check for the possible cause, replace the fuses

■ **Transmitter poorly audible (3,5 MHz)**

Possible cause: antenna not properly tuned or installed, radiator wire whipped out of the socket

Solution: check for the antenna installation, then tune the antenna again

■ **Transmitter poorly audible (144 MHz)**

Possible cause: antenna too low or tilted, element(s) lost

Solution: check for the antenna installation

■ **Transmitter transmits wrong code or in wrong time**

Possible cause: wrong settings, clock start

Solution: check for the settings, restart the clock

■ **After pushing the TEST button, no tuner operation starts**

Possible cause: VHF/no antenna

Solution: check for the connected antenna

7 SPECIFICATIONS

■ General

Supply	built-in Lithium-Ion accumulator 7,4V/4,6Ah
Charger:	built-in, automatic, supplied from 12V DC source
Operating period	
continuous operation	8 hours (high power), 18 hours (low power)
intervals operation	40 hours (high power), 90 hours (low power)
Operating temperature range	-10...+ 60°C
Storage temperature range	-20...+ 60°C
Covering	IP65
Dimensions	80(Wx45(H)x220(D) mm (without projections)
Weight	700 g

■ 3,5 MHz transmitter

Carrier frequency	16 channels (3,51 ... 3,66 MHz)
Mode	A1A (CW)
Output RF power @ 50 ohm	HIGH: 3 W, LOW: 1 W
Spurious emissions:	less than -70 dB
Antenna tuner:	built-in automatic
Antenna tuner range:	30...600 ohm unbalanced
Antenna:	vertical wire 8 m + 8 m counterpoise

■ 144 MHz transmitter

Carrier frequency	16 channels (144,2 ... 145,5 MHz)
Mode	A2A, keyed carrier, AM 75%
Modulation:	sinewave, 800/1000/1200 Hz
Output RF power @ 50 ohm	HIGH: 3 W PEP, LOW: 1 W PEP
Spurious emissions:	less than -70 dB
Antenna:	omnidirectional turnstile

■ Logic unit

Transmitted codes	MOE, MOI, MOS, MOH, MO5, MO, A ... Z
Keying speed:	35,50,70 or 100 PARIS
Timing schedules:	60/240 (s, transmit/space), 30/120, 30/270, 12/48, 15/45, 30/30, 15/15, 60/60, 60/120
Delayed start:	any time up to 24 hours in the future
Time stability	+2 ppm (approx. 1 s/week) kept by RTC
Language:	ENG, CZE

8 TECHNICAL INFORMATION

Front panel connector pin-out:

1	144 MHz antenna
2	common ground
3	3,5 MHz antenna
4	12V charger input
5	3,5 MHz band enable

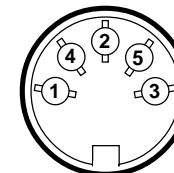

External 12V source: CANON DB9 male, pin 1: minus, pin 5: plus. **DO NOT CONNECT OTHER PINS!**

9 OPTIONS

- Switching 12V/6A DC supply source for 1-6 transmitters
- Synchro cable
- Setting device for the transmitters network
- Foxoring whip antenna
- Various transmitting antennas
- Cable lock

10 WARRANTY, SERVICE

Should this equipment malfunction under normal use, it will be repaired without charge for a period of one year from the date of purchase.

The customer shall not have any claim under this warranty for repair or adjustment expenses if the trouble is caused by improper, rough or careless treatment or mechanical damage, by a fire or other natural calamity or by improper repair or adjustment made by anyone other than manufacturer.

The warranty does not cover the accumulators.

After the first year of use manufacturer offers the free of charge adjustment and check of the equipment including the recalibration of clock and synthesizer. Any other information, service or modifications are provided by the manufacturer:

Jiří Mareček, OK2BWN, Obřanská 593, CZ-664 01 Bílovice nad Svitavou
phone/fax +420 545227041, e-mail: marecek@sky.cz



Jiří Mareček, OK2BWN
CZ-664 01 Bílovice nad Svitavou, Obřanská 593
phone +420602531222, phone/fax +420 545227041
e-mail: marecek@sky.cz, <http://www.marecek.sky.cz>